

DATA SHEET

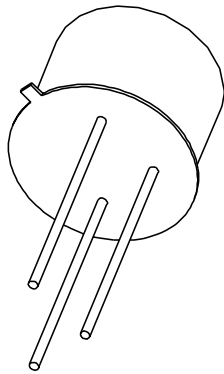

BC140; BC141 NPN medium power transistors

Product specification
Supersedes data of September 1994
File under Discrete Semiconductors, SC04

1997 May 12

NPN medium power transistors

BC140; BC141

FEATURES

- High current (max. 1 A)
- Low voltage (max. 60 V).

APPLICATIONS

- General purpose switching and amplification.

DESCRIPTION

NPN medium power transistor in a TO-39 metal package.
 PNP complements: BC160 and BC161.

PINNING

PIN	DESCRIPTION
1	emitter
2	base
3	collector, connected to case

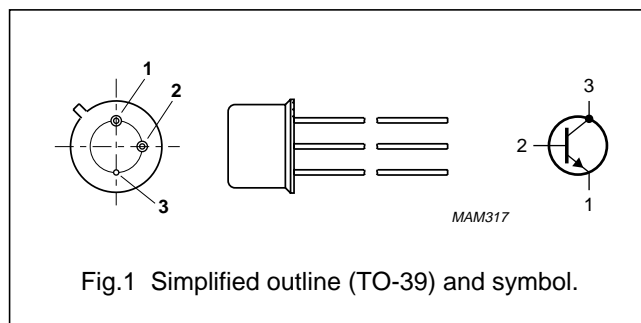

Fig.1 Simplified outline (TO-39) and symbol.

QUICK REFERENCE DATA

SYMBOL	PARAMETER	CONDITIONS	MIN.	TYP.	MAX.	UNIT
V _{CBO}	collector-base voltage	open emitter				
	BC140		–	–	80	V
	BC141		–	–	100	V
V _{CEO}	collector-emitter voltage	open base				
	BC140		–	–	40	V
	BC141		–	–	60	V
I _{CM}	peak collector current		–	–	1.5	A
P _{tot}	total power dissipation	T _{case} ≤ 45 °C	–	–	3.7	W
h _{FE}	DC current gain	I _C = 100 mA; V _{CE} = 1 V				
	BC140-10; BC141-10		63	100	160	
	BC140-16; BC141-16		100	160	250	
f _T	transition frequency	I _C = 50 mA; V _{CE} = 10 V; f = 100 MHz	50	–	–	MHz

NPN medium power transistors

BC140; BC141

LIMITING VALUES

In accordance with the Absolute Maximum Rating System (IEC 134).

SYMBOL	PARAMETER	CONDITIONS	MIN.	MAX.	UNIT
V _{CBO}	collector-base voltage	open emitter	–	80	V
	BC140			100	V
V _{CEO}	collector-emitter voltage	open base	–	40	V
	BC141			60	V
V _{EBO}	emitter-base voltage	open collector	–	7	V
I _C	collector current (DC)		–	1	A
I _{CM}	peak collector current		–	1.5	A
I _{BM}	peak base current		–	200	mA
P _{tot}	total power dissipation	T _{case} ≤ 45 °C	–	3.7	W
T _{stg}	storage temperature		–65	+150	°C
T _j	junction temperature		–	175	°C
T _{amb}	operating ambient temperature		–65	+150	°C

THERMAL CHARACTERISTICS

SYMBOL	PARAMETER	CONDITIONS	VALUE	UNIT
R _{th j-a}	thermal resistance from junction to ambient	in free air	200	K/W
R _{th j-c}	thermal resistance from junction to case		35	K/W

NPN medium power transistors

BC140; BC141

CHARACTERISTICS

$T_{amb} = 25\text{ °C}$ unless otherwise specified.

SYMBOL	PARAMETER	CONDITIONS	MIN.	TYP.	MAX.	UNIT
I_{CBO}	collector cut-off current	$I_E = 0; V_{CB} = 60\text{ V}$	–	10	100	nA
		$I_E = 0; V_{CB} = 60\text{ V}; T_j = 150\text{ °C}$	–	10	100	μA
I_{EBO}	emitter cut-off current	$I_C = 0; V_{EB} = 5\text{ V}$	–	–	100	nA
h_{FE}	DC current gain BC140-10; BC141-10 BC140-16; BC141-16	$I_C = 100\text{ }\mu\text{A}; V_{CE} = 1\text{ V}$	–	40	–	
			–	90	–	
h_{FE}	DC current gain BC140-10; BC141-10 BC140-16; BC141-16	$I_C = 100\text{ mA}; V_{CE} = 1\text{ V}$	63	100	160	
			100	160	250	
h_{FE}	DC current gain BC140-10; BC141-10 BC140-16; BC141-16	$I_C = 1\text{ A}; V_{CE} = 1\text{ V}$	–	20	–	
			–	30	–	
V_{CEsat}	collector-emitter saturation voltage	$I_C = 1\text{ A}; I_B = 100\text{ mA}$	–	0.6	1	V
V_{BE}	base-emitter voltage	$I_C = 1\text{ A}; V_{CE} = 1\text{ V}$	–	1.2	1.8	V
C_c	collector capacitance	$I_E = i_e = 0; V_{CB} = 10\text{ V}; f = 1\text{ MHz}$	–	–	25	pF
C_e	emitter capacitance	$I_C = i_c = 0; V_{EB} = 0.5\text{ V}; f = 1\text{ MHz}$	–	–	80	pF
f_T	transition frequency	$I_C = 50\text{ mA}; V_{CE} = 10\text{ V}; f = 100\text{ MHz}$	50	–	–	MHz
Switching times (between 10% and 90% levels)						
t_{on}	turn-on time	$I_{Con} = 100\text{ mA}; I_{Bon} = 5\text{ mA};$ $I_{Boff} = -5\text{ mA}$	–	–	250	ns
t_{off}	turn-off time		–	–	850	ns

NPN medium power transistors

BC140; BC141

PACKAGE OUTLINE

Metal-can cylindrical single-ended package; 3 leads

SOT5/11

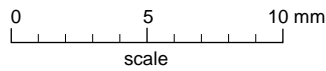
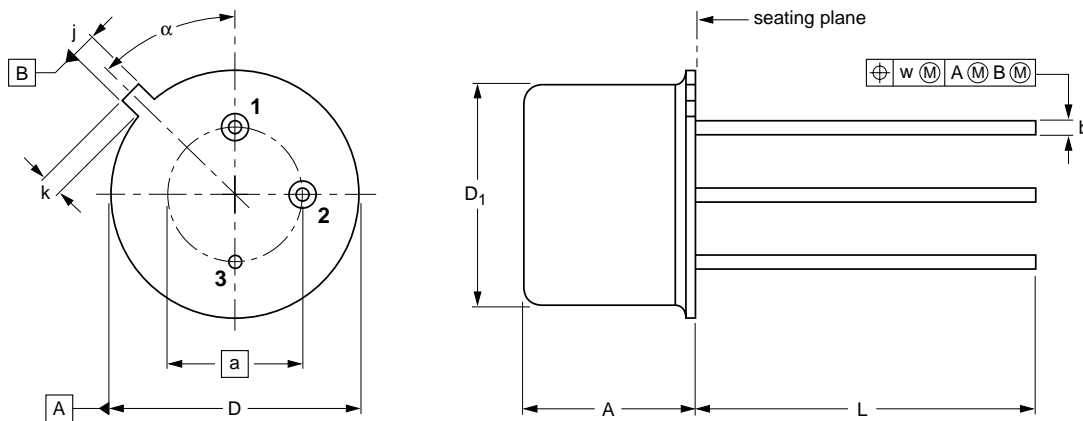

DIMENSIONS (mm are the original dimensions)

UNIT	A	a	b	D	D ₁	j	k	L	w	α
mm	6.60 6.35	5.08	0.48 0.41	9.39 9.08	8.33 8.18	0.85 0.75	0.95 0.75	14.2 12.7	0.2	45°

OUTLINE VERSION	REFERENCES				EUROPEAN PROJECTION	ISSUE DATE
	IEC	JEDEC	EIAJ			
SOT5/11		TO-39				97-04-11

NPN medium power transistors

BC140; BC141

DEFINITIONS

Data Sheet Status	
Objective specification	This data sheet contains target or goal specifications for product development.
Preliminary specification	This data sheet contains preliminary data; supplementary data may be published later.
Product specification	This data sheet contains final product specifications.
Limiting values	
Limiting values given are in accordance with the Absolute Maximum Rating System (IEC 134). Stress above one or more of the limiting values may cause permanent damage to the device. These are stress ratings only and operation of the device at these or at any other conditions above those given in the Characteristics sections of the specification is not implied. Exposure to limiting values for extended periods may affect device reliability.	
Application information	
Where application information is given, it is advisory and does not form part of the specification.	

LIFE SUPPORT APPLICATIONS

These products are not designed for use in life support appliances, devices, or systems where malfunction of these products can reasonably be expected to result in personal injury. Philips customers using or selling these products for use in such applications do so at their own risk and agree to fully indemnify Philips for any damages resulting from such improper use or sale.