

NPN SILICON TRANSISTORS

- STMicroelectronics PREFERRED SALESTYPES

DESCRIPTION

The BD135 and BD139 are silicon epitaxial planar NPN transistors in Jedec SOT-32 plastic package, designed for audio amplifiers and drivers utilizing complementary or quasi complementary circuits.

The complementary PNP types are BD136 and BD140 respectively.

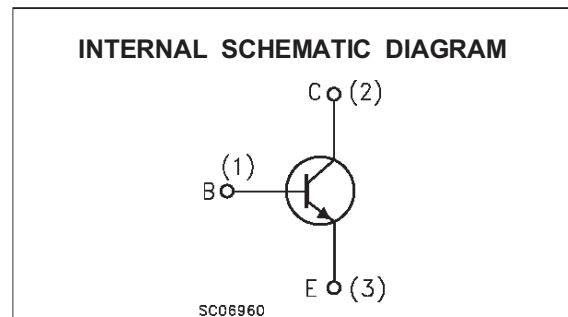
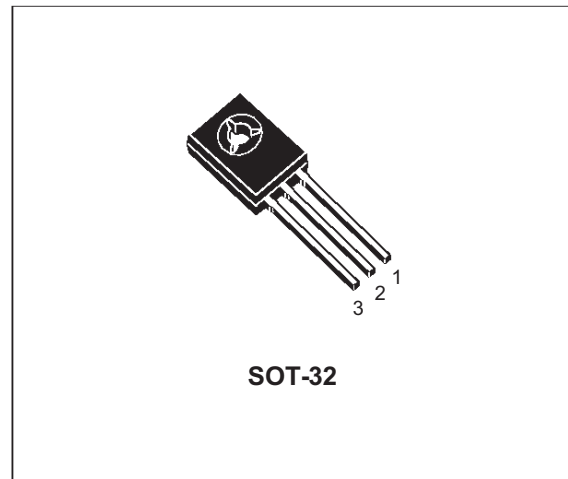

ABSOLUTE MAXIMUM RATINGS

Symbol	Parameter	Value		Unit
		BD135	BD139	
V_{CBO}	Collector-Base Voltage ($I_E = 0$)	45	80	V
V_{CEO}	Collector-Emitter Voltage ($I_B = 0$)	45	80	V
V_{EBO}	Emitter-Base Voltage ($I_C = 0$)	5		V
I_C	Collector Current	1.5		A
I_{CM}	Collector Peak Current	3		A
I_B	Base Current	0.5		A
P_{tot}	Total Dissipation at $T_c \leq 25\text{ }^\circ\text{C}$	12.5		W
P_{tot}	Total Dissipation at $T_{amb} \leq 25\text{ }^\circ\text{C}$	1.25		W
T_{stg}	Storage Temperature	-65 to 150		$^\circ\text{C}$
T_j	Max. Operating Junction Temperature	150		$^\circ\text{C}$

BD135 / BD139

THERMAL DATA

$R_{thj-case}$	Thermal Resistance Junction-case	Max	10	$^{\circ}C/W$
----------------	----------------------------------	-----	----	---------------

ELECTRICAL CHARACTERISTICS ($T_{case} = 25^{\circ}C$ unless otherwise specified)

Symbol	Parameter	Test Conditions	Min.	Typ.	Max.	Unit
I_{CBO}	Collector Cut-off Current ($I_E = 0$)	$V_{CB} = 30 V$ $V_{CB} = 30 V \quad T_C = 125^{\circ}C$			0.1 10	μA μA
I_{EBO}	Emitter Cut-off Current ($I_C = 0$)	$V_{EB} = 5 V$			10	μA
$V_{CE(sus)*}$	Collector-Emitter Sustaining Voltage	$I_C = 30 mA$ for BD135 for BD139	45 80			V V
$V_{CE(sat)*}$	Collector-Emitter Saturation Voltage	$I_C = 0.5 A \quad I_B = 0.05 A$			0.5	V
V_{BE*}	Base-Emitter Voltage	$I_C = 0.5 A \quad V_{CE} = 2 V$			1	V
h_{FE*}	DC Current Gain	$I_C = 5 mA \quad V_{CE} = 2 V$ $I_C = 0.5 A \quad V_{CE} = 2 V$ $I_C = 150 mA \quad V_{CE} = 2 V$	25 25 40		250	
h_{FE}	h_{FE} Groups	$I_C = 150 mA \quad V_{CE} = 2 V$ for BD139 group 10	63		160	

* Pulsed: Pulse duration = 300 μs , duty cycle 1.5 %

Safe Operating Area

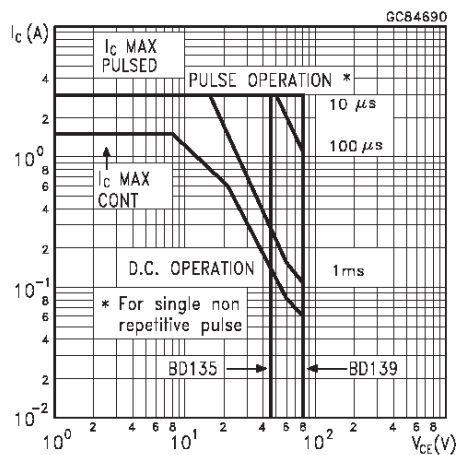

SOT-32 (TO-126) MECHANICAL DATA

DIM.	mm			inch		
	MIN.	TYP.	MAX.	MIN.	TYP.	MAX.
A	7.4		7.8	0.291		0.307
B	10.5		10.8	0.413		0.445
b	0.7		0.9	0.028		0.035
b1	0.49		0.75	0.019		0.030
C	2.4		2.7	0.040		0.106
c1	1.0		1.3	0.039		0.050
D	15.4		16.0	0.606		0.629
e		2.2			0.087	
e3	4.15		4.65	0.163		0.183
F		3.8			0.150	
G	3		3.2	0.118		0.126
H			2.54			0.100

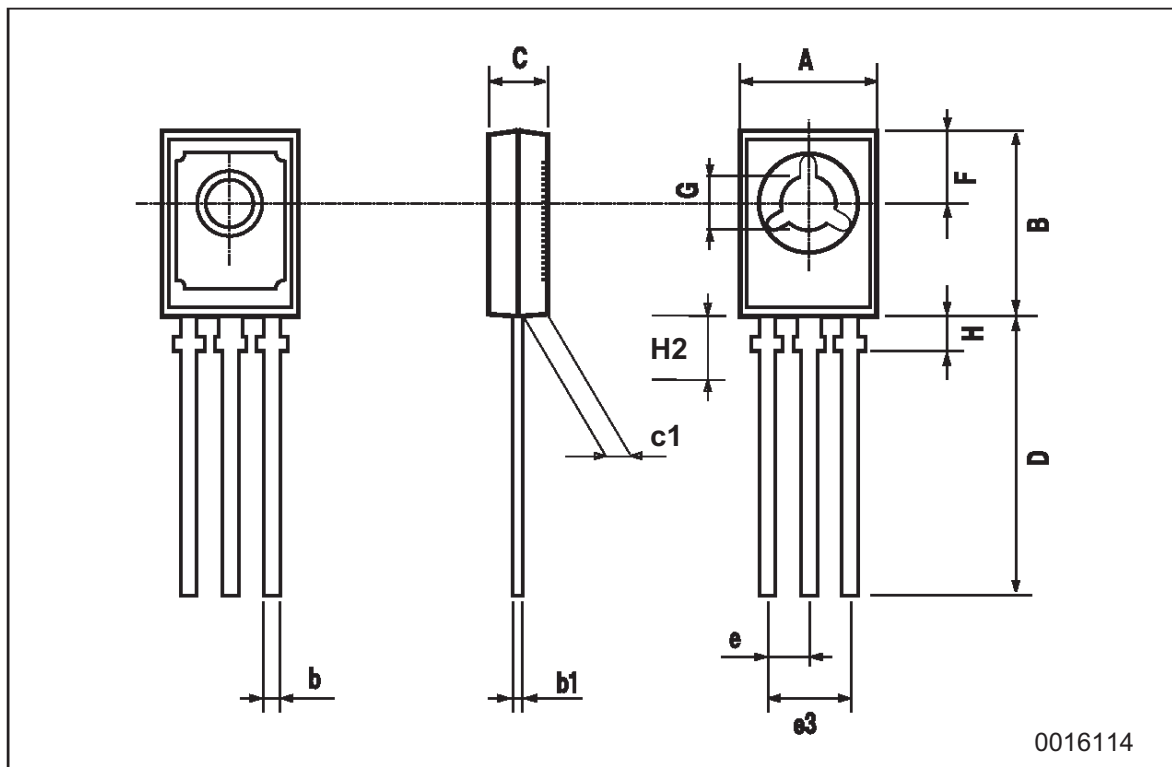

Information furnished is believed to be accurate and reliable. However, STMicroelectronics assumes no responsibility for the consequences of use of such information nor for any infringement of patents or other rights of third parties which may result from its use. No license is granted by implication or otherwise under any patent or patent rights of STMicroelectronics. Specification mentioned in this publication are subject to change without notice. This publication supersedes and replaces all information previously supplied. STMicroelectronics products are not authorized for use as critical components in life support devices or systems without express written approval of STMicroelectronics.

The ST logo is a trademark of STMicroelectronics

© 1999 STMicroelectronics – Printed in Italy – All Rights Reserved

STMicroelectronics GROUP OF COMPANIES

Australia - Brazil - Canada - China - France - Germany - Italy - Japan - Korea - Malaysia - Malta - Mexico - Morocco - The Netherlands - Singapore - Spain - Sweden - Switzerland - Taiwan - Thailand - United Kingdom - U.S.A.

<http://www.st.com>