

**DUAL LOW-VOLTAGE POWER AMPLIFIER**

- SUPPLY VOLTAGE DOWN TO 1.8V
- LOW CROSSOVER DISTORSION
- LOW QUIESCENT CURRENT
- BRIDGE OR STEREO CONFIGURATION

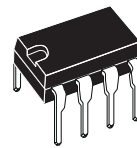

**MINIDIP**

**ORDERING NUMBER : TDA2822M**

**DESCRIPTION**

The TDA2822M is a monolithic integrated circuit in 8 lead Minidip package. It is intended for use as dual audio power amplifier in portable cassette players and radios.

**PIN CONNECTION (Top view)**

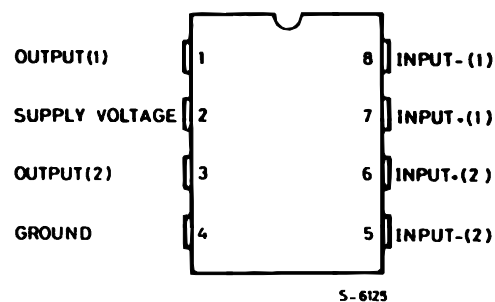

# TDA2822M

## SCHEMATIC DIAGRAM

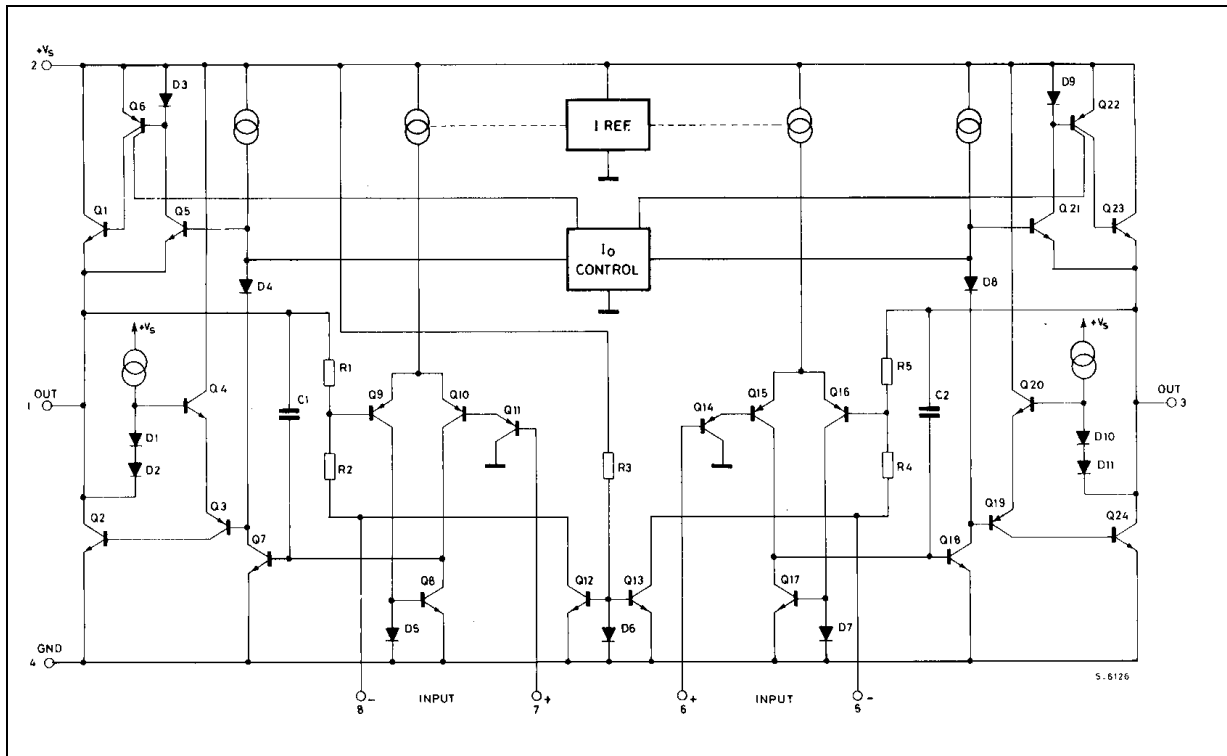

## ABSOLUTE MAXIMUM RATINGS

Symbol	Parameter	Value	Unit
$V_s$	Supply Voltage	15	V
$I_o$	Peak Output Current	1	A
$P_{tot}$	Total Power Dissipation at $T_{amb} = 50\text{ }^\circ\text{C}$ at $T_{case} = 50\text{ }^\circ\text{C}$	1 1.4	W W
$T_{stg}, T_j$	Storage and Junction Temperature	- 40, + 150	$^\circ\text{C}$

## THERMAL DATA

Symbol	Parameter	Value	Unit
$R_{th\ j-amb}$	Thermal Resistance Junction-ambient	Max. 100	$^\circ\text{C/W}$
$R_{th\ j-case}$	Thermal Resistance Junction-pin (4)	Max. 70	$^\circ\text{C/W}$

**ELECTRICAL CHARACTERISTICS** ( $V_S = 6V$ ,  $T_{amb} = 25^\circ C$ , unless otherwise specified)

Symbol	Parameter	Test Conditions	Min.	Typ.	Max.	Unit
<b>STEREO</b> (test circuit of Figure 1)						
$V_S$	Supply Voltage		1.8		15	V
$V_o$	Quiescent Output Voltage	$V_S = 3V$		2.7 1.2		V V
$I_d$	Quiescent Drain Current			6	9	mA
$I_b$	Input Bias Current			100		nA
$P_o$	Output Power (each channel) ( $f = 1kHz$ , $d = 10\%$ )	$R_L = 32\Omega$ $V_S = 9V$ $V_S = 6V$ $V_S = 4.5V$ $V_S = 3V$ $V_S = 2V$ $R_L = 16\Omega$ $V_S = 6V$ $R_L = 8\Omega$ $V_S = 9V$ $V_S = 6V$ $R_L = 4\Omega$ $V_S = 6V$ $V_S = 4.5V$ $V_S = 3V$	90 15 170 300 450	300 120 60 20 5 220 1000 380 650 320 110		mW
$d$	Distortion ( $f = 1kHz$ )	$R_L = 32\Omega$ $P_o = 40mW$ $R_L = 16\Omega$ $P_o = 75mW$ $R_L = 8\Omega$ $P_o = 150mW$		0.2 0.2 0.2		% % %
$G_v$	Closed Loop Voltage Gain	$f = 1kHz$	36	39	41	dB
$\Delta G_v$	Channel Balance				$\pm 1$	dB
$R_i$	Input Resistance	$f = 1kHz$	100			k $\Omega$
$e_N$	Total Input Noise	$R_S = 10k\Omega$ B = Curve A B = 22Hz to 22kHz		2 2.5		$\mu V$ $\mu V$
SVR	Supply Voltage Rejection	$f = 100Hz$ , $C_1 = C_2 = 100\mu F$	24	30		dB
$C_s$	Channel Separation	$f = 1kHz$		50		dB
<b>BRIDGE</b> (test circuit of Figure 2)						
$V_S$	Supply Voltage		1.8		15	V
$I_d$	Quiescent Drain Current	$R_L = \infty$		6	9	mA
$V_{os}$	Output Offset Voltage (between the outputs)	$R_L = 8\Omega$			$\pm 50$	mV
$I_b$	Input Bias Current			100		nA
$P_o$	Output Power ( $f = 1kHz$ , $d = 10\%$ )	$R_L = 32\Omega$ $V_S = 9V$ $V_S = 6V$ $V_S = 4.5V$ $V_S = 3V$ $V_S = 2V$ $R_L = 16\Omega$ $V_S = 9V$ $V_S = 6V$ $V_S = 3V$ $R_L = 8\Omega$ $V_S = 6V$ $V_S = 4.5V$ $V_S = 3V$ $R_L = 4\Omega$ $V_S = 4.5V$ $V_S = 3V$ $V_S = 2V$	320 50 900 200	1000 400 200 65 8 2000 800 120 1350 700 220 1000 350 80		mW
$d$	Distortion	$P_o = 0.5W$ , $R_L = 8\Omega$ , $f = 1kHz$		0.2		%
$G_v$	Closed Loop Voltage Gain	$f = 1kHz$		39		dB
$R_i$	Input Resistance	$f = 1kHz$	100			k $\Omega$
$e_N$	Total Input Noise	$R_S = 10k\Omega$ B = Curve A B = 22Hz to 22kHz		2.5 3		$\mu V$ $\mu V$
SVR	Supply Voltage Rejection	$f = 100Hz$		40		dB
B	Power Bandwidth (-3dB)	$R_L = 8\Omega$ , $P_o = 1W$		120		kHz

Figure 1 : Test Circuit (Stereo)

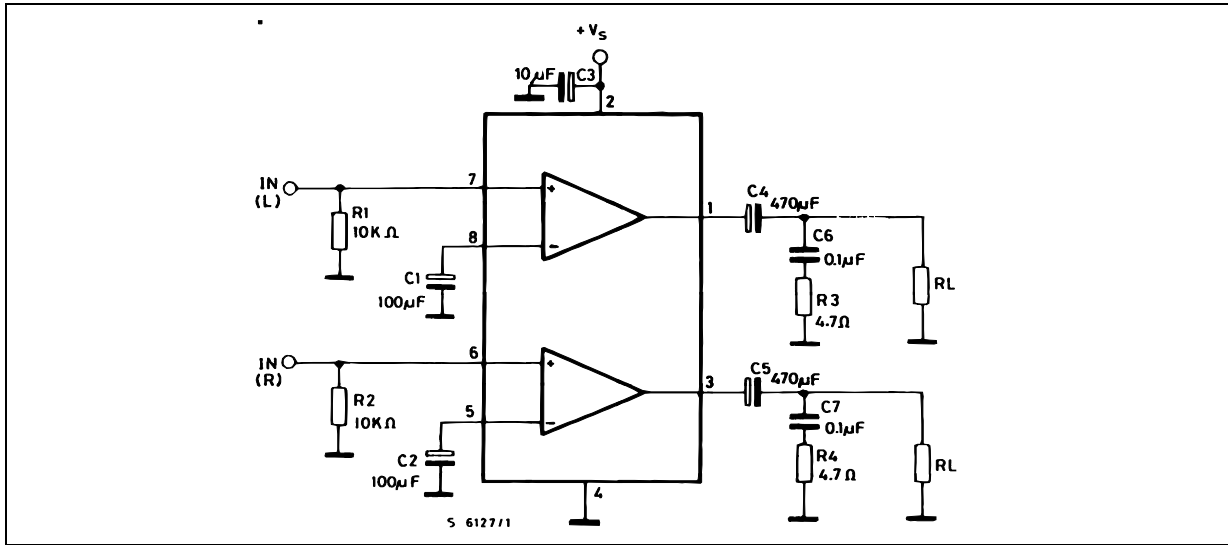

Figure 2 : Test Circuit (Bridge)

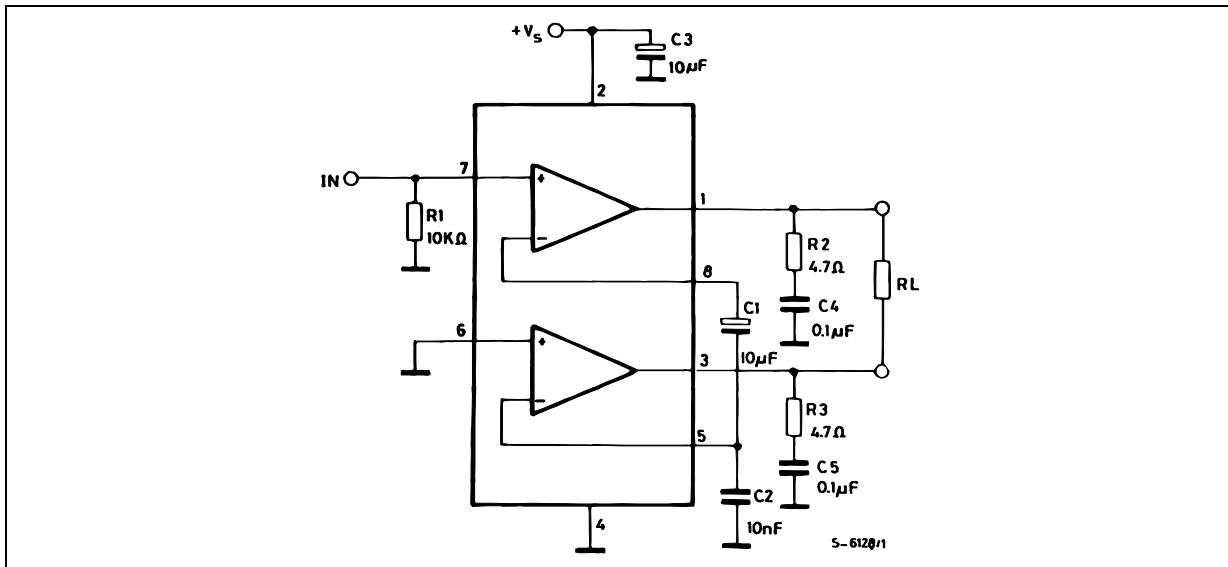

Figure 3 : P.C. Board and Components Layout of the Circuit of Figure 1

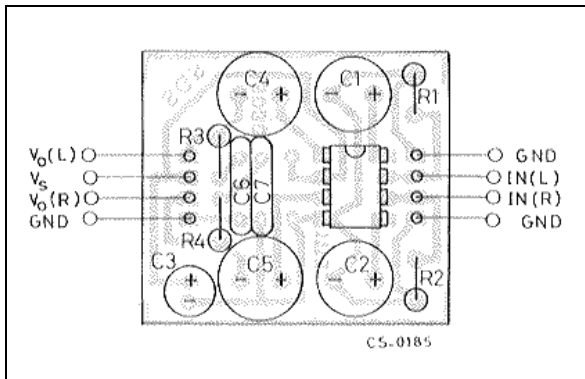
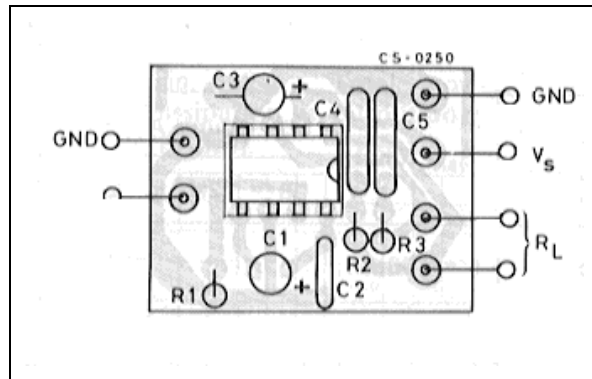
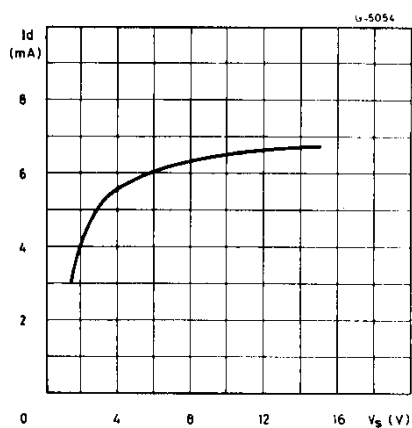

Figure 4 : P.C. Board and Components Layout of the Circuit of Figure 2



**Figure 5 :** Quiescent Current versus Supply Voltage



**Figure 6 :** Supply Voltage Rejection versus Frequency

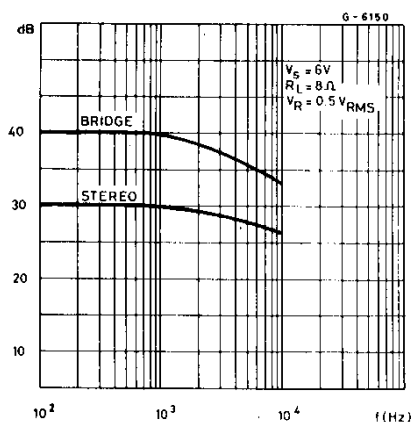

**Figure 7 :** Output Power versus Supply Voltage (THD = 10%, f = 1kHz Stereo)

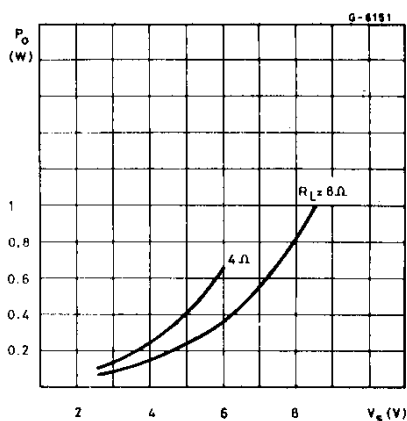

**Figure 8 :** Distorsion versus Output Power (Stereo)

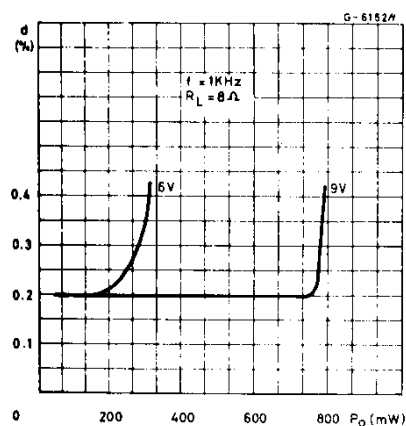

**Figure 9 :** Distorsion versus Output Power (Stereo)

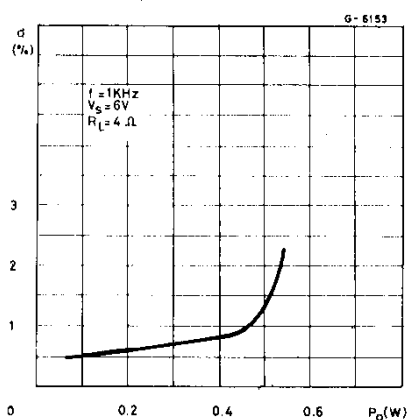

**Figure 10 :** Output Power versus Supply Voltage (Bridge)

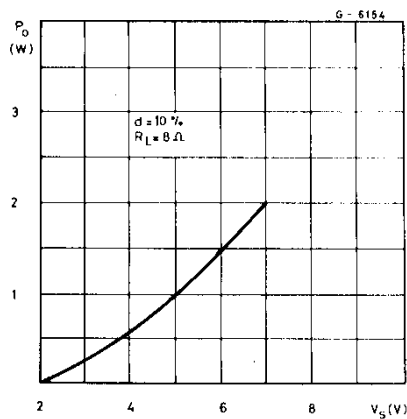

**Figure 11 :** Distorsion versus Output Power (Bridge)

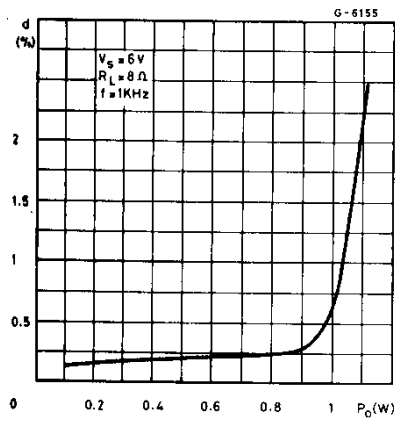

**Figure 12 :** Total Power Dissipation versus Output Power (Bridge)

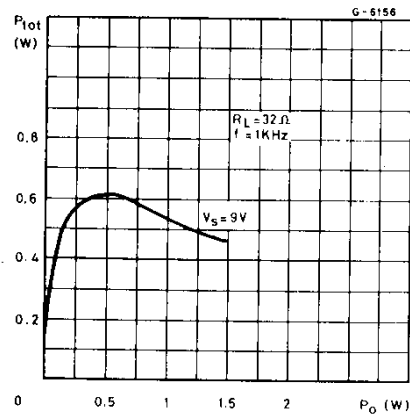

**Figure 13 :** Total Power Dissipation versus Output Power (Bridge)

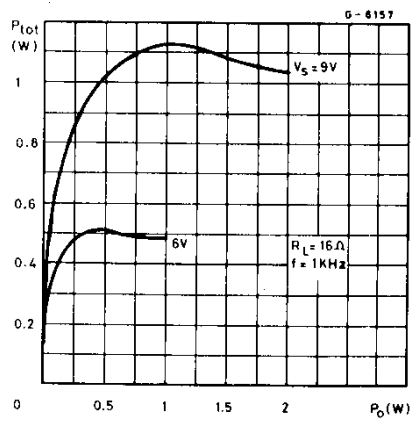

**Figure 14 :** Total Power Dissipation versus Output Power (Bridge)

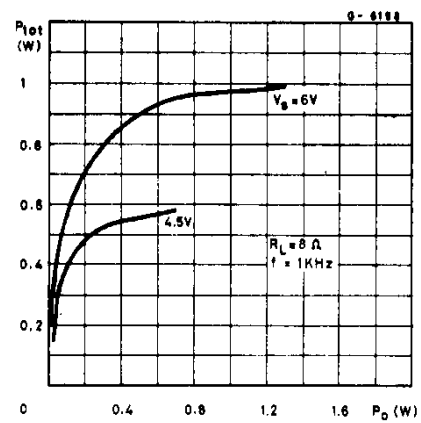

**Figure 15 :** Total Power Dissipation versus Output Power (Bridge)

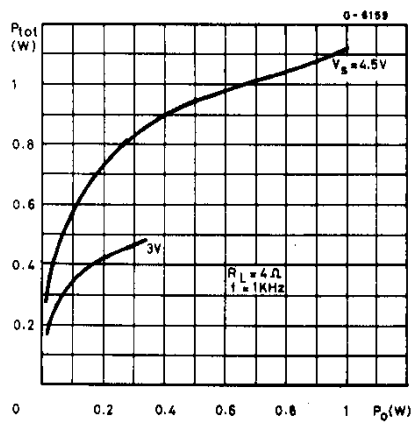

Figure 16 : Typical Application in Portable Players

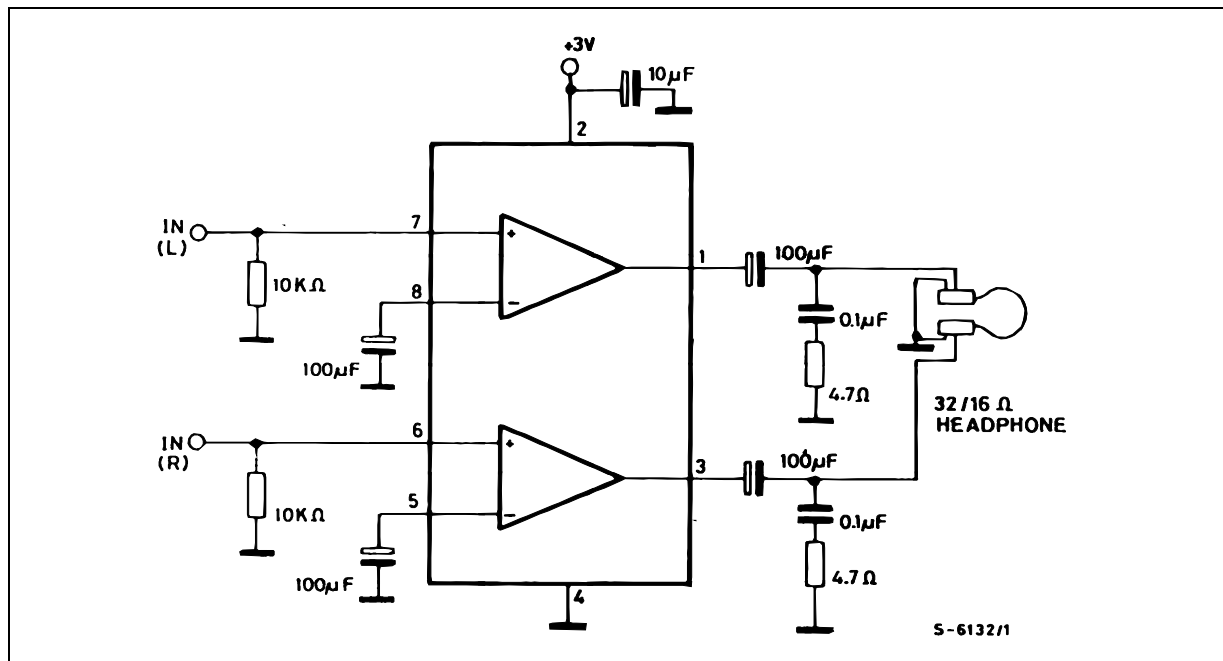
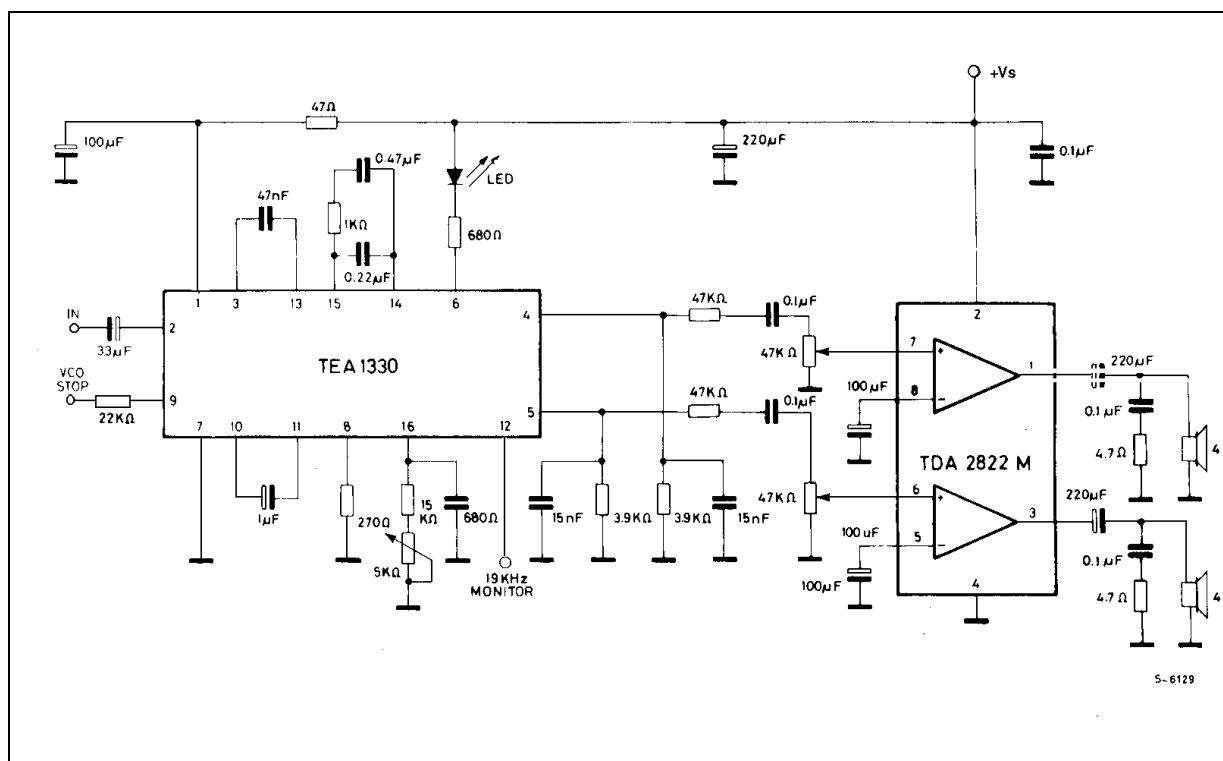
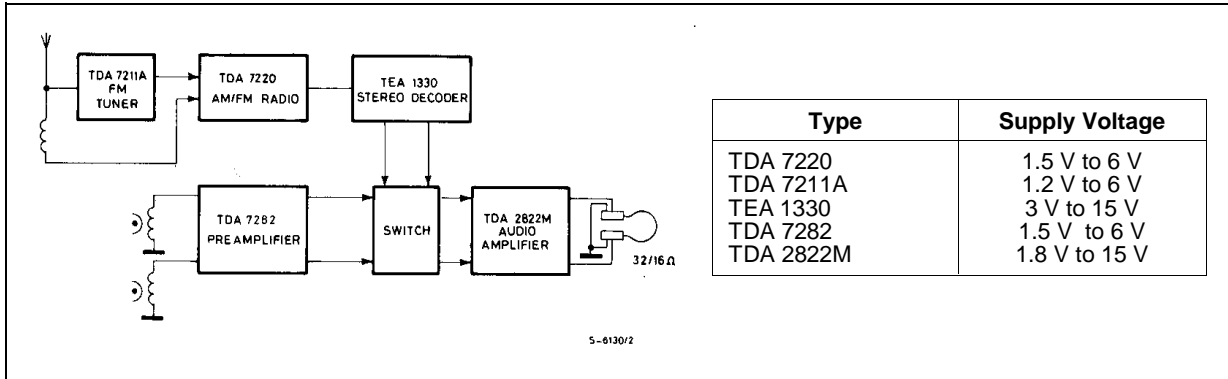

Figure 17 : Application in Portable Radio Receivers



# TDA2822M

**Figure 18 : Portable Radio Cassette Players**



**Figure 19 : Portable Stereo Radios**

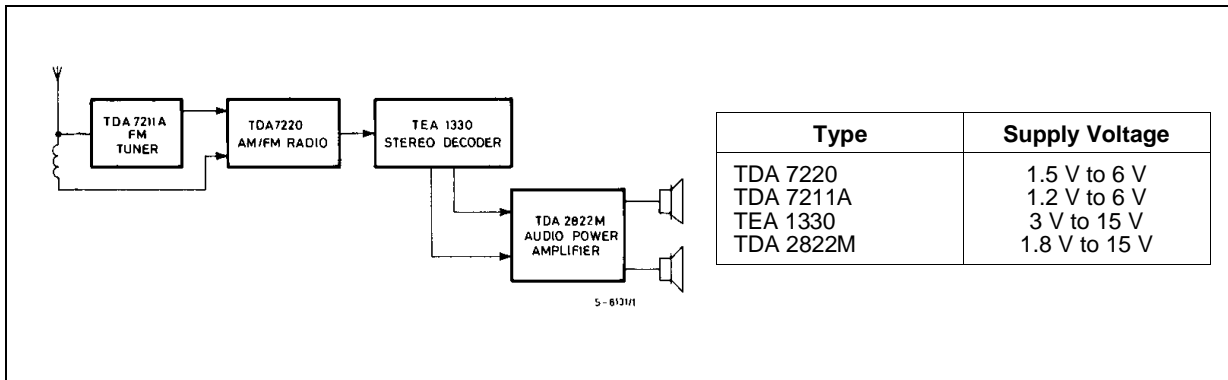

**Figure 20 : Low Cost Application in Portable Players (using only one 100μF output capacitor)**

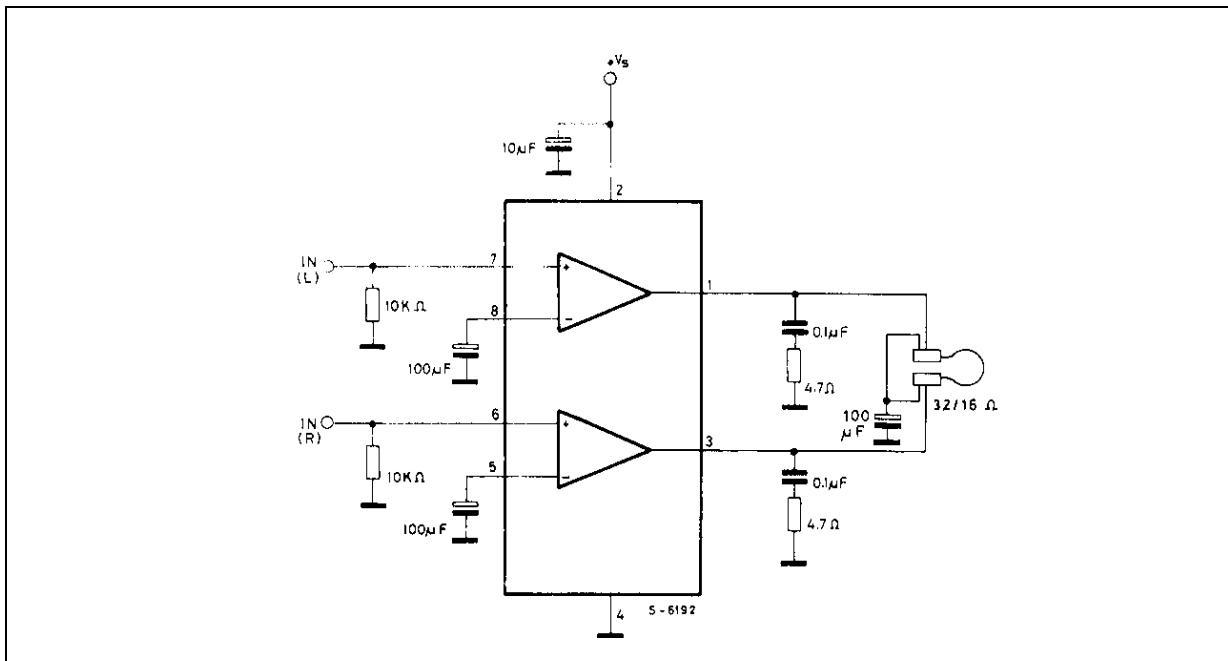
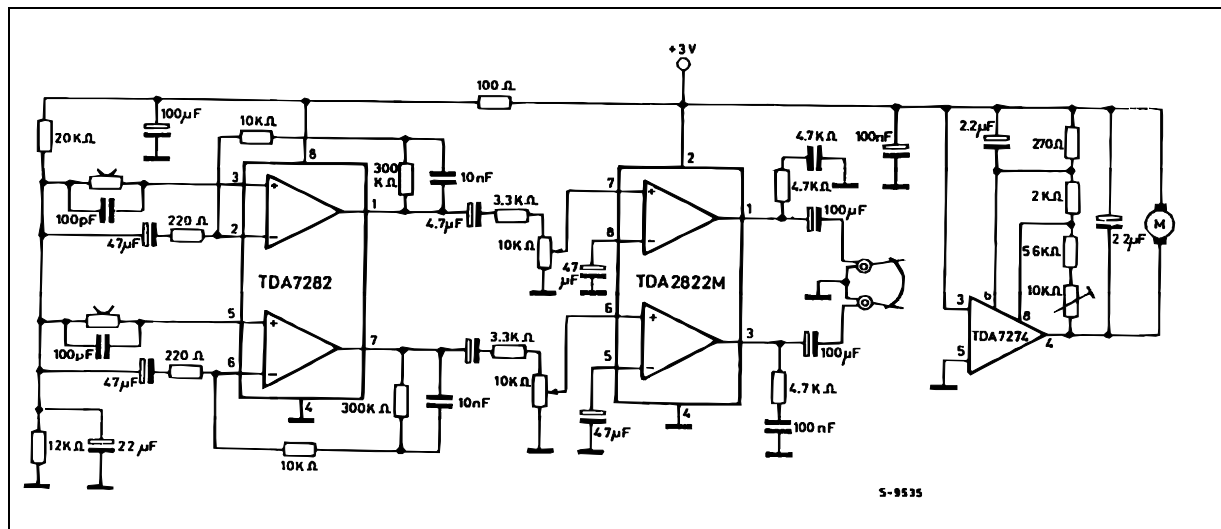

Figure 21 : 3V Stereo Cassette Player with Motot Speed Control



# TDA2822M

## MINIDIP PACKAGE MECHANICAL DATA

DIM.	mm			inch		
	MIN.	TYP.	MAX.	MIN.	TYP.	MAX.
A		3.32			0.131	
a1	0.51			0.020		
B	1.15		1.65	0.045		0.065
b	0.356		0.55	0.014		0.022
b1	0.204		0.304	0.008		0.012
D			10.92			0.430
E	7.95		9.75	0.313		0.384
e		2.54			0.100	
e3		7.62			0.300	
e4		7.62			0.300	
F			6.6			0.260
I			5.08			0.200
L	3.18		3.81	0.125		0.150
Z			1.52			0.060

